

# ***Snappi Wheelbase*** & Interface

*Versatility  
at its best!*



*Transit  
brackets  
included  
as standard*

*The lightweight and robust Snappi chassis provides a unique gas strut operated tilt in space facility of 0 to 40 degrees. Swivelling front castors aid manoeuvrability.*

*The quick release Snappi Interface has been designed to accommodate a wide range of manufacturers seating systems.*

*A comprehensive range of accessories are available, including an equipment carrying tray, shopping basket, rain cover, sun canopy and frame padding.*

*The interfacing system incorporates a unique 2 stage catch, designed to prevent accidental release of the seat from the chassis.*

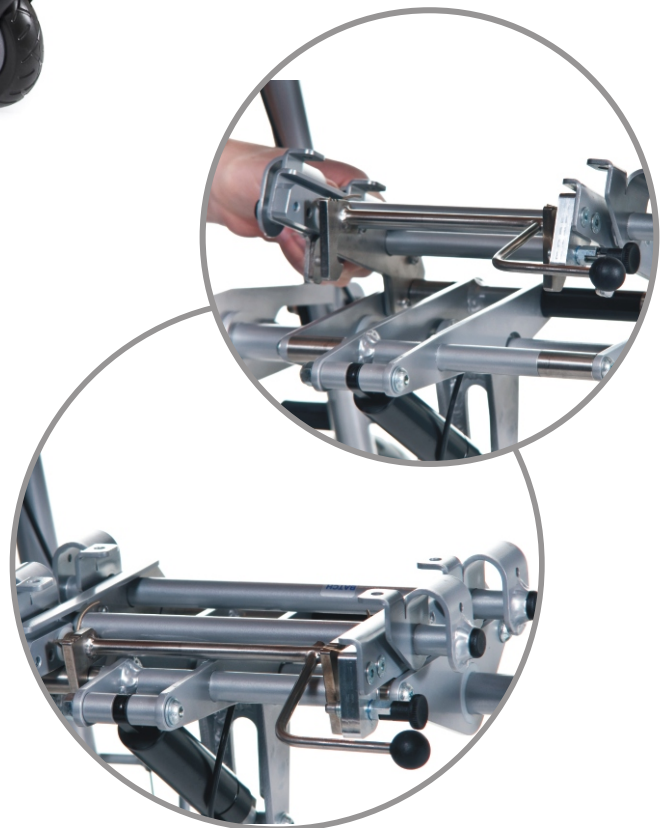

**Tendercare**

Tendercare Ltd  
PO BOX 3091  
Littlehampton  
BN16 2WF

Tel: 01903 726161  
Fax: 01903 734083  
Email: [info@tendercareltd.com](mailto:info@tendercareltd.com)  
Web: [www.tendercareltd.com](http://www.tendercareltd.com)

# Snappi Wheelbase & Interface

## Technical Information



Snappi with Moulded Seat



Moulded Seat Rear View



Size 1 With Modular



Size 2 With Modular



Snugseat Snappi



Snappi Pushchair

The Snappi Wheelbase and Interface have been successfully crash tested to ISO 7176/19, with all Tendercare's seating systems.

Specifications	Size 1 (mm)	Size 2 (mm)
<b>Wheelbase Size (AxBxC)</b>	944 x 571 x 992	1052 x 684 x 998
<b>Buggy Folded (AxBxC)</b>	771 x 571 x 573	798 x 684 x 560
<b>Seat Tilt in Space</b>	0 - 40°	0 - 40°
<b>Weight</b>	10kg	11kg
<b>Max. Weight*</b>	50kg	50kg
<b>Max Seat Width</b>	350mm	415mm

\*Maximum weight includes seat unit, occupant and all accessories.

