

CE

Tendercare

WORKSHOP MANUAL

For

MULTI RANGER LIFTING SEAT

Please read these instructions carefully
before attempting to maintain the lifting seat

Warning

The cartons are heavy
Moving and unpacking must be performed with care

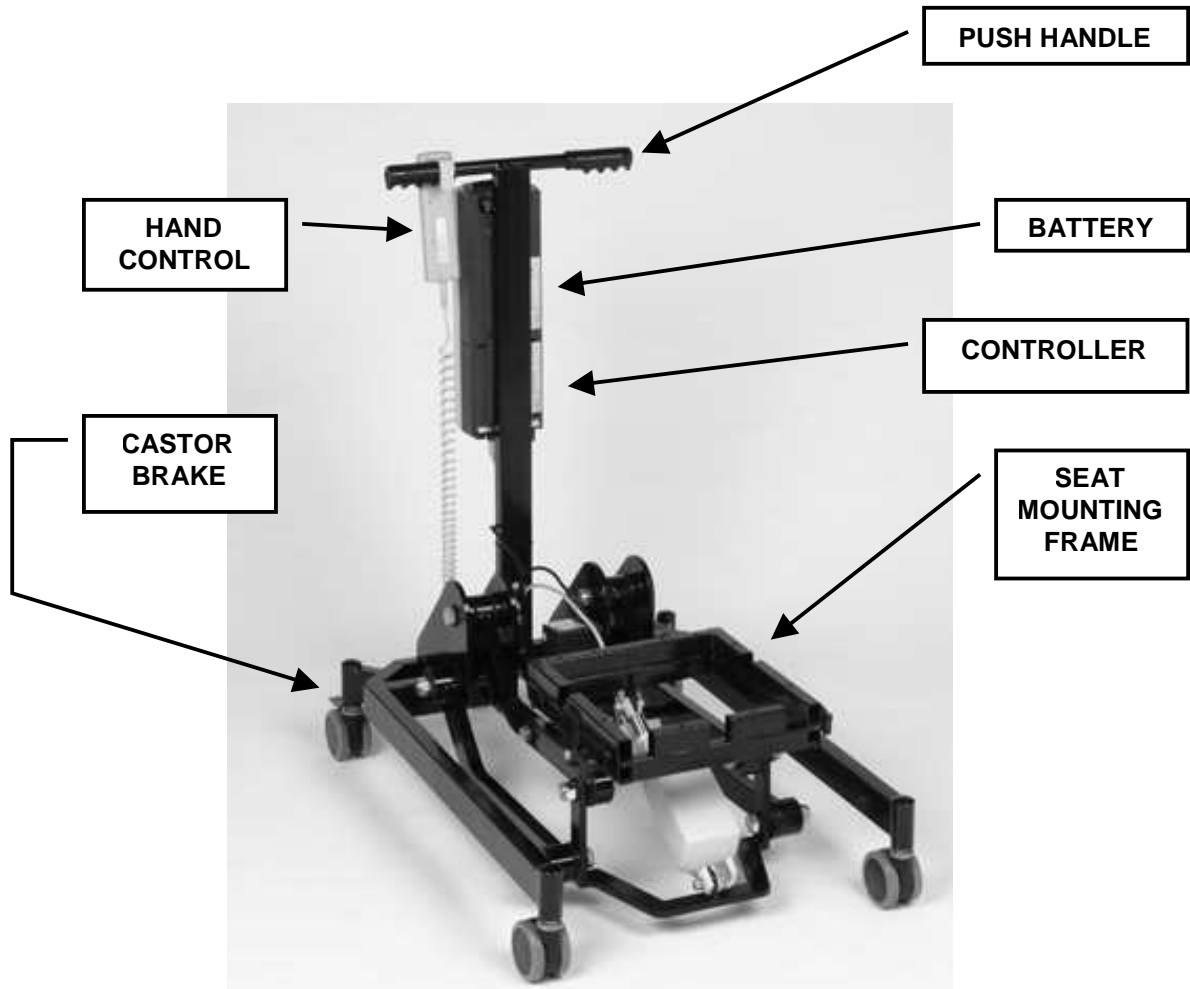

TENDERCARE

MULTI RANGER LIFTING SEAT

CONTENTS

| ITEM | DESCRIPTION | PAGE |
|------|---|------|
| 1 | Your Multi Ranger Lifting Seat Manual..... | 4 |
| 2 | Transit Packaging..... | 4 |
| 3 | Tools and Torque Settings..... | 5 |
| 4 | Preparing for Use..... | 5 |
| | 4.1 Attaching the Push Handle..... | 5 |
| | 4.2 Special Seat..... | 6 |
| | 4.3 Fitting the Battery..... | 7 |
| | 4.4 Controller Connections..... | 7 |
| | 4.5 Battery Charger..... | 8 |
| | 4.6 Emergency Stop..... | 8 |
| | 4.7 Controls and Actuators..... | 9 |
| | 4.8 Brakes..... | 9 |
| 5 | Cleaning..... | 10 |
| 6 | Maintenance..... | 10 |
| | 6.1 Routine Maintenance..... | 10 |
| | 6.2 Six Monthly Maintenance Procedure..... | 10 |
| 7 | Repairs..... | 10 |
| | 7.1 Replacing Braked and Front Castors..... | 11 |
| | 7.2 Replacing Lifting Actuator..... | 11 |
| | 7.3 Replacing Seat Tilt Actuator..... | 12 |
| | 7.4 Replacing Controller / Battery..... | 14 |
| 8 | Important Points..... | 15 |
| 9 | Dimensions and Weights..... | 15 |
| 10 | Parts List..... | 15 |
| 11 | Trouble Shooting..... | 16 |

1. Your Multi Ranger Lifting Seat Manual

The purpose of this manual is to help you get the best from your lifting seat. It does this by telling you how to complete those maintenance and repair tasks that can be carried out by a competent person. The manual also tells you when you should contact the manufacturer who is: -

Tendercare Ltd
PO Box 3091, Littlehampton, BN16 2WF
Tel (01903) 726161
Fax (01903) 734083
Email info@tendercareltd.com

2. Transit Packaging

Warning: - the transit packaging is heavy, moving and unpacking must be done with care. Observe all lifting and handling regulations.

- 1) The lifting seat is supplied in packaging of approximate size and weight 600 mm wide x 800 mm deep x 500 mm high. Weight of carton 50 kg.
- 2) Open the carton and remove any packages or packing, which could obstruct the removal of the product.
- 3) When you have removed the contents and checked you have all the items listed below you should dispose of the packaging at your local recycling centre.
- 4) Check that you have the following items: -

| Item | Component | Number | Yes | No |
|------|--|--------|-----|----|
| 1. | Multi Ranger Lifting Seat | 1 | | |
| 2. | Push handle | 1 | | |
| 3. | Push handle fixing bolts, nuts and washers | 2 | | |
| 4. | Battery | 1 | | |
| 5. | Battery charger | 1 | | |
| 6. | User Manual | 1 | | |

Check all items for damage to paintwork, alignment, welds etc.

If any items are damaged or missing please contact Tendercare, preferably by fax 01903-734083 within 36 hours of delivery.

The general assembly of the Mini Tilt lifting seat is illustrated on page 2.

A parts list is given on page 15.

3. Tools and Torque Settings

The following tools are required to dismantle and reassemble the lifting seat: -

Spanners and sockets: - 13mm, 17, 19mm and 24mm.

Hexagon Keys: - 7mm.

Torque Wrench: - range 0 to 60 Nm.

Torque settings: -

| Spanner Size | Torque Nm |
|--------------|-----------|
| 13mm | 25 |
| 17mm | 35 |
| 19mm | 45 |
| 24mm | 54 |

4. Preparing for use

The Multi Ranger may be delivered fully assembled ready for use. The Multi Ranger may also be supplied in packaging. In this case some assembly will be required. For assembly follow the instructions below and in the user manual.

When assembled and ready for use the following pre-delivery procedures should be carried out to check that the lifting seat has not suffered damage during transit and that all features operate satisfactorily.

Warning: - When working on or operating the lifting seat, ensure that you avoid any danger of catching your fingers in moving parts.

4.1 Attaching the Push Handle – make sure the push handle has been properly attached.

The push handle should be attached to the lifting seat frame as follows: -

The push handle is supplied complete with two M8 Setscrews, Nyloc nuts and Washers.

Hold the push handle so that the battery / controller is facing towards the back of the frame then insert the push handle into the socket in the frame. (See Fig 1 below).

Lock the push handle to the frame by fitting a washer over a setscrew and screw it into the back of the frame. Using a 13 mm spanner tighten to 25Nm. Keeping the spanner on the bolt head to prevent it moving fit the Nyloc nut onto the screw and tighten to 25Nm using a second 13 mm spanner. (See Fig 2 below). Repeat the operation for the second screw.

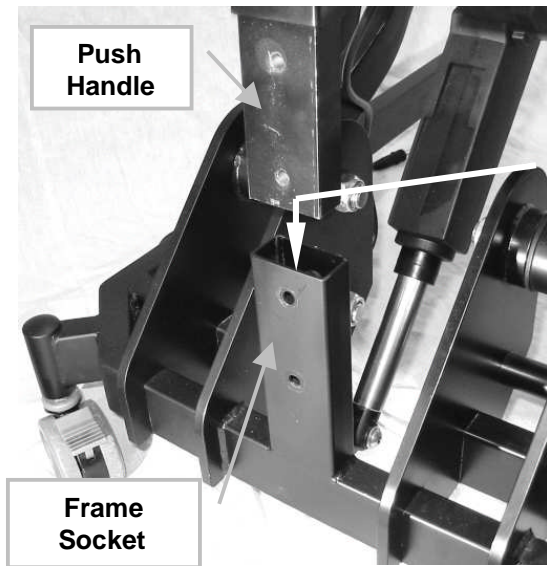

Fig 1
INSERTING PUSHHANDLE

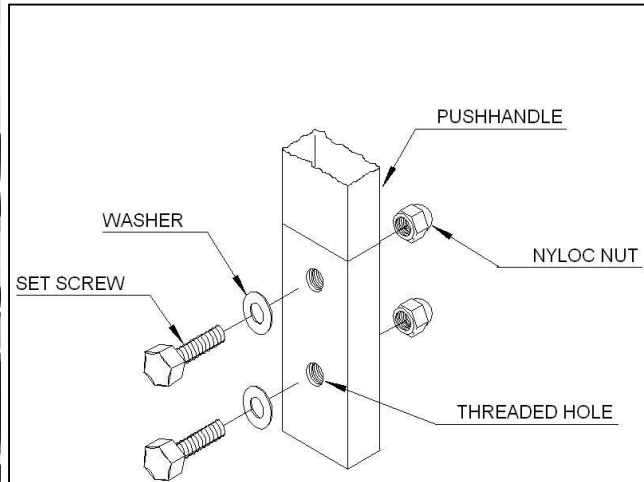

Fig 2
INSERTING LOCKING SCREWS

4.2 Special Seat - make sure the seat has been securely attached.

The seat unit may be fitted to the mounting frame before it is supplied. Alternatively, if the seat unit is supplied separately a competent person must follow the seat manufacturers instructions when fitting and adjusting the seat.

Check that the seat has been properly and securely fitted to the lifting seat and that all seat components are in place and in a presentable condition.

The seat mounting frame arrangement is show in figure 3 below.

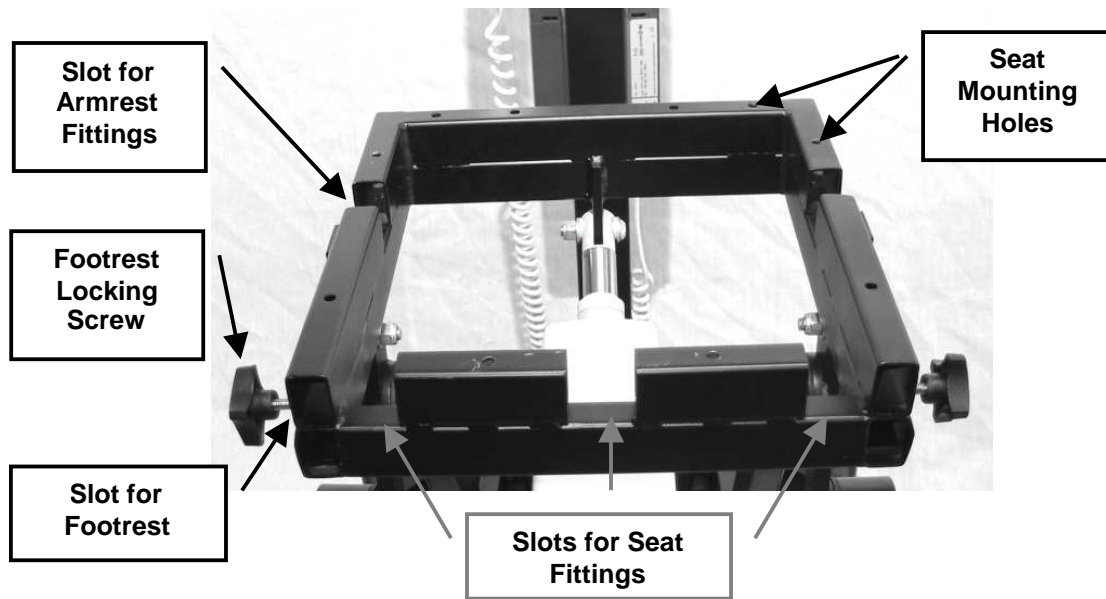

FIG 3 SEAT MOUNTING FRAME

4.3 Fitting the Battery – Make sure the battery is properly fitted.

The battery sits on top of the controller, which is on the rear face of the push handle. (See Fig 4 opposite). It is attached to its mounting bracket by a spring-loaded catch at the top. To fit the battery, place it on top of the controller and lock into place at the top by clicking the spring loaded catch on the battery over the mounting bracket on the push handle.

To remove the battery, squeeze the spring-loaded catch and lift off the controller.

Warning: - The battery is quite heavy take care not to drop it.

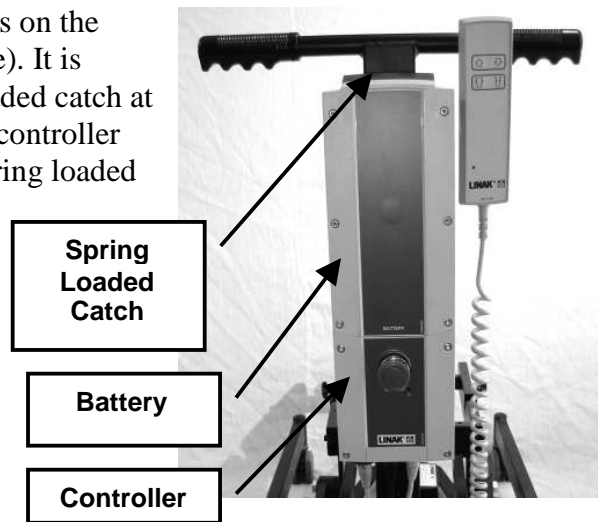

**FIG 3
BATTERY MOUNTING**

4.4 Controller Connections – check that all plugs are properly fitted.

The controller is supplied with all connections made. Check that all the plugs are fully inserted in the correct positions see Fig 4 below.

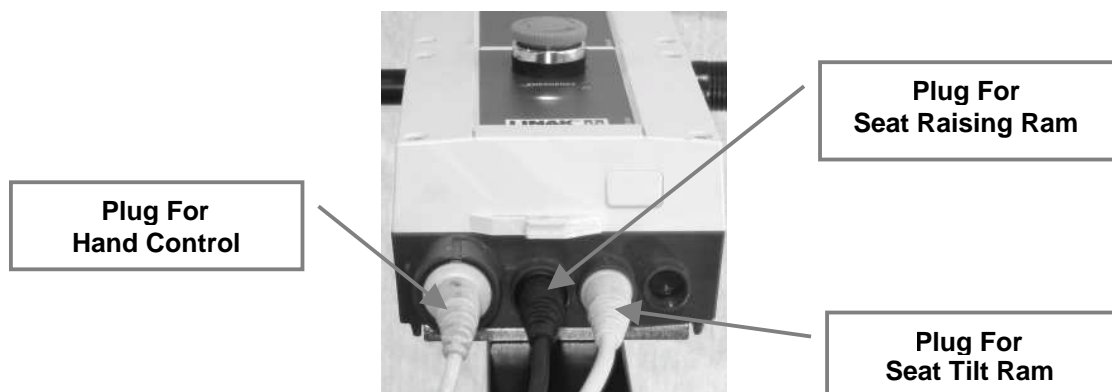
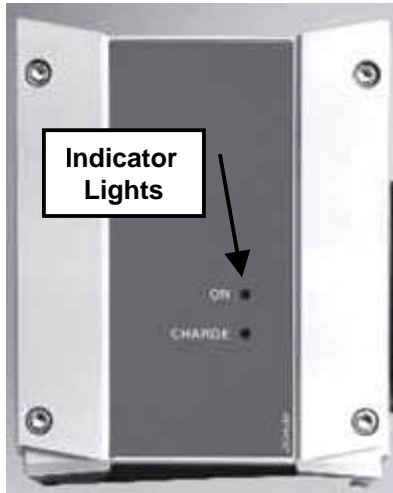

Fig 4 Controller Connections

4.5 Battery Charger – mount in a suitable position and check operation.



**Fig 5
BATTERY
CHARGER**

Mount the wall bracket and battery charger on a suitable wall using wall plugs and screws (*not supplied*). The bracket and charger should be firmly attached to a wall where there is sufficient room to give 50 mm clearance to the side, above and below the charger and battery. It should also be fitted near to an electricity socket.

Check operation of charger as follows: -

Fit the battery to the charger by placing it on top of the charger and locking into place at the top by clicking the spring loaded catch on the battery over the charger-mounting bracket.

Plug in the charger and switch on the supply. The green light indicates the charger is connected to the mains. The yellow light indicates that the battery is properly connected and is charging. The battery will take approximately 4 hours to charge. (See Fig 5).

To remove the battery switch off the charger at the mains then squeeze the spring loaded catch on top of the battery and lift the battery off the charger.

Safety Tip: - When the charger is not in use switch off the mains supply or pull the plug out in order to prevent unintentional operation.

4.6 Emergency Stop – Check operation.

Fit the battery as described in Section 4.3 above.

Check operation of the emergency stop, which is on the controller. (See Fig 6).

Push in the stop button and the actuators should not move when the hand control is operated.

Release the emergency stop by twisting the stop button clockwise and check the actuators move when the hand control is operated.



**Push to turn OFF
Twist to the right to
turn ON**

**Fig 6
EMERGENCY STOP**

4.7 Controls and Actuators – Check operation.

Check operation of the hand control and actuators. Make sure the hand control operates as described below and that the actuators move through their full range.

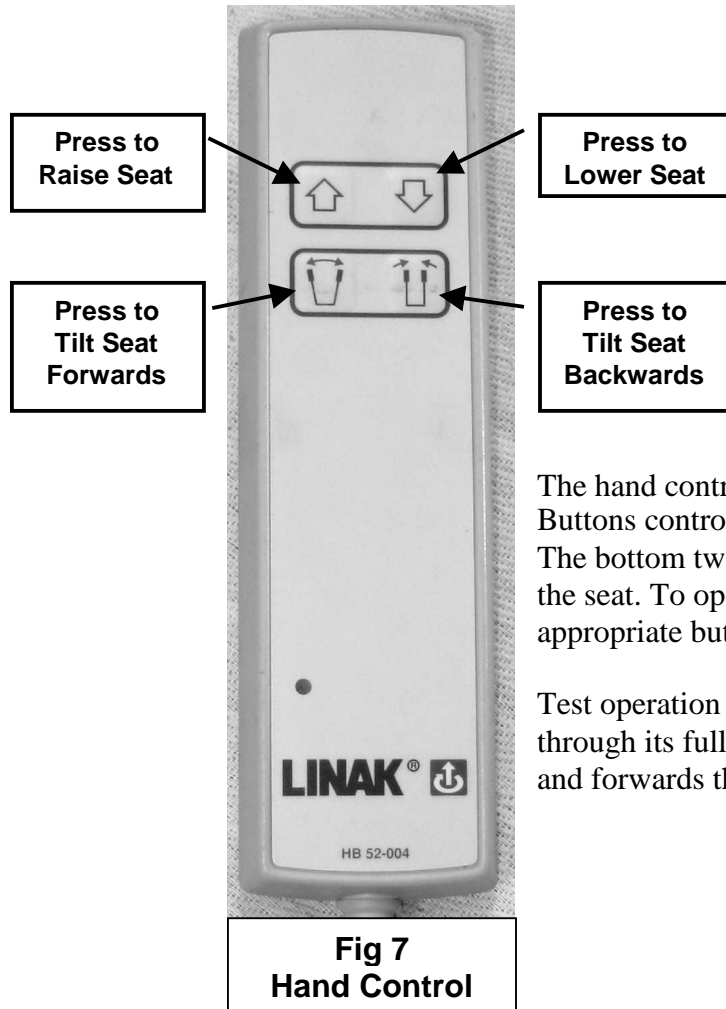

The hand control has four buttons. The top two Buttons control the raising and lowering of the seat. The bottom two buttons controls the angle of tilt of the seat. To operate the controls press the appropriate button. (See Fig 7 opposite).

Test operation by raising and lowering the seat through its full range. Also tilt the seat backwards and forwards through its full range.

4.8 Brakes – check operation.

The Multi Ranger is fitted with two brakes one on each rear castor wheel. (See Fig 8). Check operation of both brakes.

Put the brakes on by pressing the brake pedal down. When the brakes are on the wheels should not move.

Release the brakes by lifting the pedal up. The wheels should rotate freely.

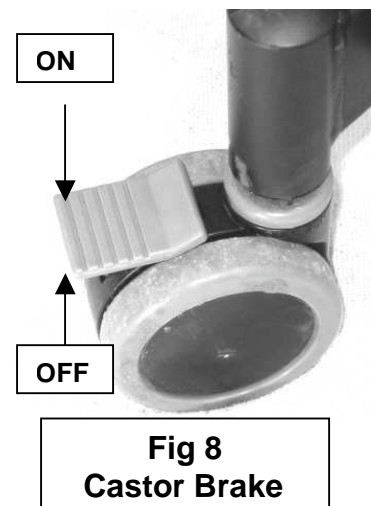

5. Cleaning

- 1) Whenever the Multi Ranger gets dirty it should be cleaned using a damp cloth and then dried thoroughly.
- 2) For more stubborn stains wipe with a damp cloth using a mild solution of warm water and soap.
- 3) Never use furniture polish or spirit to clean any part of the Multi Ranger.

6. Maintenance

6.1 Routine maintenance

The user or their family can easily carry out the following tasks. No tools are required.

- 1) Keep battery charged.
- 2) Check brake operation (weekly).
- 3) Check operation of the lifting and tilt mechanism (weekly).
- 4) Clean frame when necessary (we suggest at least once a week).

6.2 Six-monthly maintenance

Someone who is a competent tradesman or repairer should only carry out this work. If a major fault is found stop using the lifting seat until it has been corrected.

- 1) Examine the frame for any damage. If frame is damaged DO NOT use the Multi Ranger until it has been repaired.
- 2) Examine all pivot points for any damage or excessive play. If there is excessive play in the pivot points DO NOT use the Multi Ranger until it has been repaired.
- 3) Examine brake, castor wheel assemblies for wear, damage and correct operation. If a brake or castor does not operate properly DO NOT use the Multi Ranger until it has been repaired. The brake and castor assemble will have to be replaced as a complete item. Instructions for doing this are given in the section 7 below.

For all other repairs refer to your issuing authority or Tendercare Ltd.

7. Repairs

Major repairs: - for all major repairs e.g. bent or damaged frame. The equipment should be returned to the factory. Contact Tendercare Ltd Customer Services on telephone 01903-726161.

An authorised repairer should only carry out the following repairs. The repairs are replacement of brake castors, front castors, actuators, controller and battery. Factory replacement components should be used in all repairs, these are available from Tendercare.

7.1 Braked and Front castors: -

- 1) Using a 19mm spanner unscrew the hexagon nut at the top of the castor swivel until the castor is removed. (See Fig 9 opposite).
- 2) Before fitting new castor apply LOCTITE thread locking compound grade 241 to the thread on the castor stem. Screw the stem into the lifting seat mounting and tighten to 54Nm.
- 3) When fitted the castor should rotate under its own weight. If it does not rotate the castor forks a number of times to ease the mechanism.
- 4) If replacing the brake castors check the operation of the brakes after fitting a new castor / brake assembly.

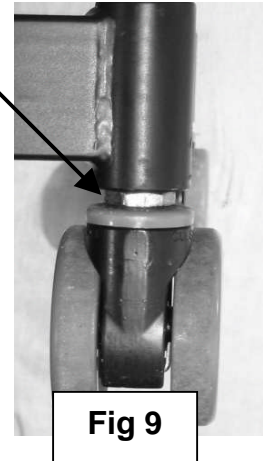

7.2 Lifting Actuator: - Replace the complete assembly if damaged or worn.

The lifting actuator is fitted between the lower rear frame and the lifting arms. (See Fig 10 below).

- 1) Remove any load on the actuator by placing a support block under the seat-mounting frame and lower the seat frame onto the block. When supported the seat should be approximately half raised to allow access to the actuator pivot on the lifting arms.
- 2) Press in the emergency stop button that is on the controller and remove the battery.
- 3) Disconnect the actuator supply lead from the controller and remove any fixings from the lead so that it is free of the frame. See "A" on fig 10.
- 4) Using a 17mm spanner and 7mm hexagon key remove the nut, washers and seat screw from the actuator mounting that is attached to the rear frame. See "B" on fig 10.
- 5) Using two 19mm spanners remove the nuts; washers and central pivot from the actuator then withdraw the actuator from the frame. See "C" on fig 10.
- 6) To fit the replacement actuator, reverse the above.

Important: - To allow the actuator pivot to move properly the Nyloc nuts should only be just touching the washer. They must not be over-tightened. If the nuts are over-tightened they will prevent the actuator from moving properly and could damage the frame.

- 7) Test the new actuator by moving the seat up and down through its full range. Make sure that the lead connecting the actuator to the controller is not caught or stretched by the movement of the mechanism.

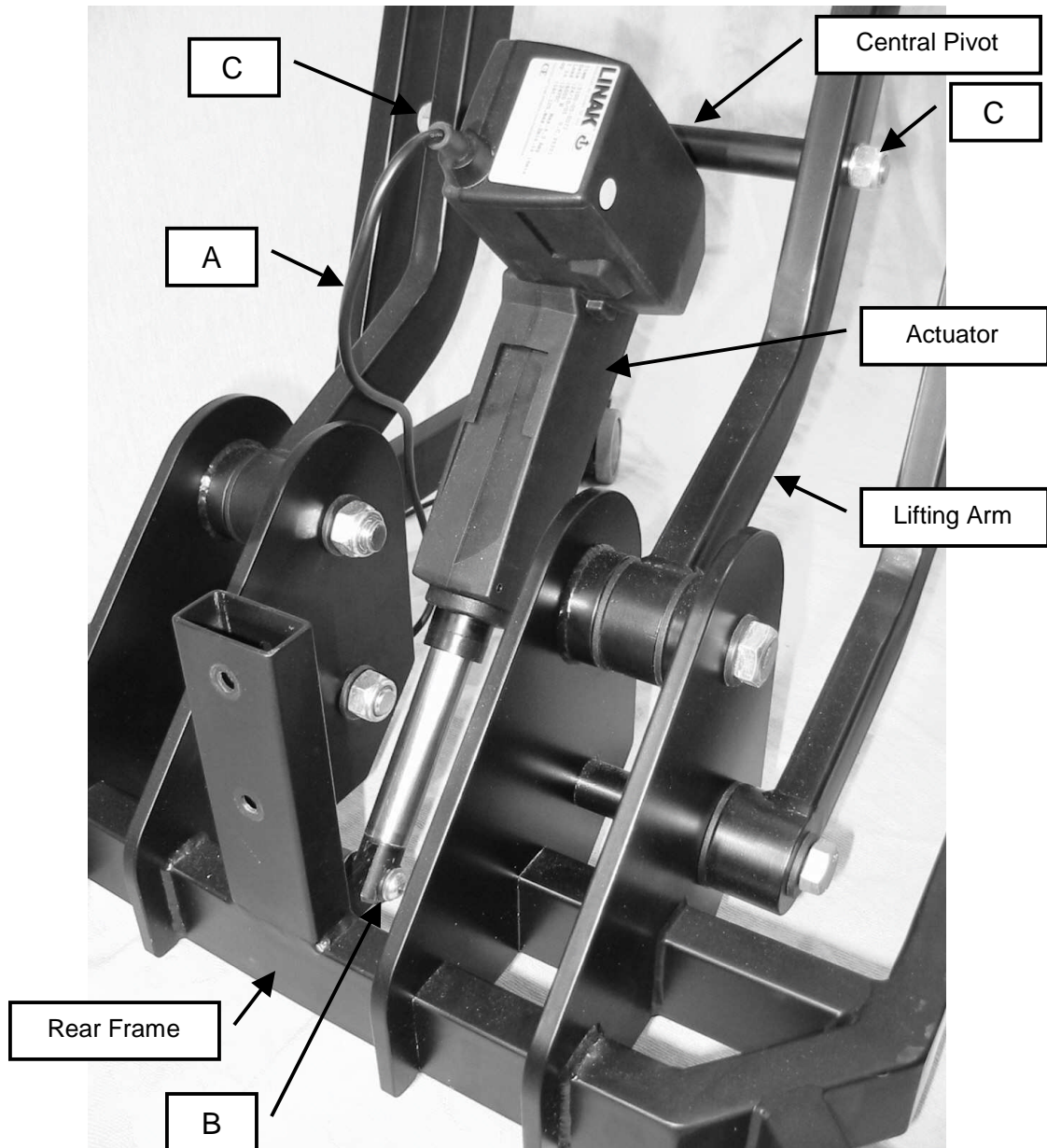

Fig 10
Lifting Actuator

7.3. Seat Tilt Actuator: - Replace the complete assembly if damaged or worn.

The lifting actuator is fitted between the seat mounting frame and the lifting arms. (See Fig 11 below).

Important: -Lock the seat in the upright position using a strut mounted between the seat and push handle. If this is not done the seat will move in an uncontrolled manner when the actuator is disconnected.

- 1) Press in the emergency stop button that is on the controller and remove the battery.
- 2) Disconnect the actuator supply lead from the controller and remove any fixings from the lead so that it is free of the frame. See “A” on fig 11.
- 3) Using a 17mm spanner and 7mm hexagon key remove the nut, washers and seat screw from the actuator mountings. See “B” on fig 11.
- 4) To fit the replacement actuator, reverse the above.

Important: - To allow the actuator pivot to move properly the Nyloc nuts should only be just touching the washer. They must not be over-tightened. If the nuts are over-tightened they will prevent the actuator from moving properly and could damage the frame.

- 5) Test the new actuator by tilting the seat forwards and backwards through its full range. Make sure that the lead connecting the actuator to the controller is not caught or stretched by the movement of the mechanism.

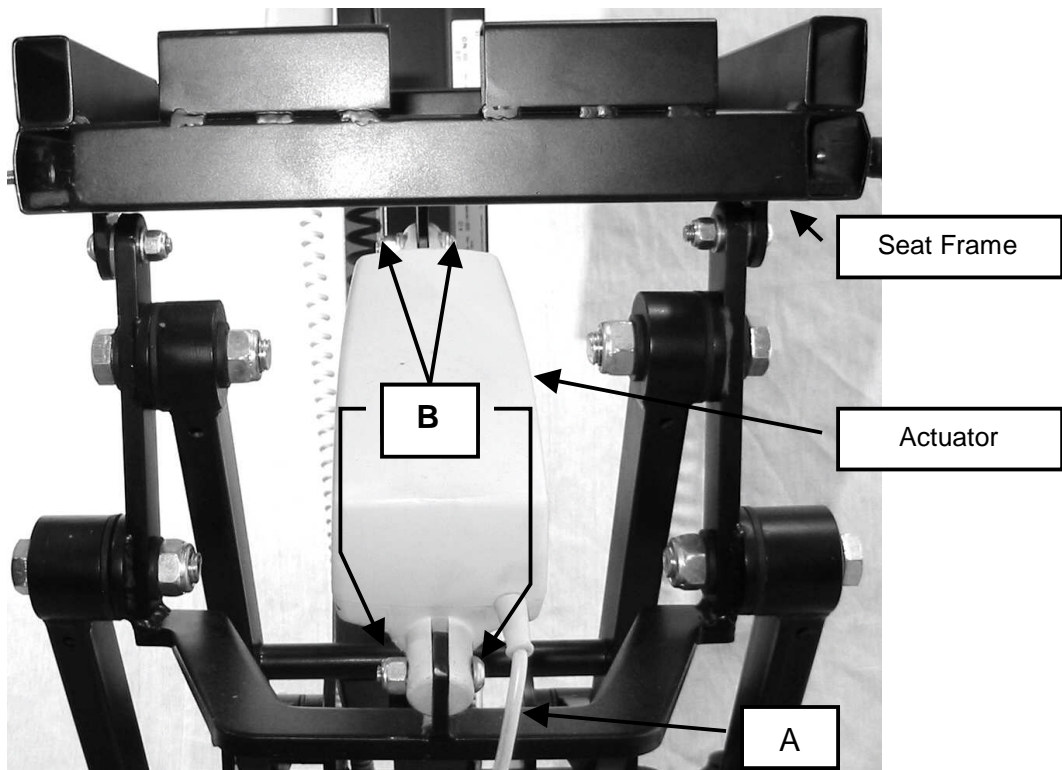

**Fig 11 - Lifting Actuator
Looking From Front of Seat**

8. Important Points

- 1) Do not reuse Nyloc nuts. Always replace with a new Nyloc nut.
- 2) Always use Loctite thread locking compound Grade 241.
- 3) Always use recommended components and parts available from Tendercare Ltd.
- 4) Do not modify or repair the frame.

9. Dimensions and Weights

The dimensions are given as a guide only. Tendercare reserves the right to change the specification without notice.

| Item | Base Unit |
|-------------------------------|-------------|
| Frame Width | 520mm |
| Frame Depth | 755mm |
| Push Handle Height | 880mm |
| Seat Tilting Facility | 0° -28° |
| Seat Height Adjustment | 270 – 780mm |
| Front Castors | 75mm Dia |
| Rear Brake Castors | 75mm Dia |
| Power Supply Integral Battery | 24V |
| Weight | 43kg |
| Maximum Carrying Capacity | 65kg |

10. Parts List

GENERAL ASSEMBLY PARTS LIST

Multi Ranger Parts List

| Ref No. | Description | Qty | Part No. |
|---------|--|-----|----------|
| 1. | 75mm braked castor | 2 | LS9247 |
| 2. | 75mm castor | 2 | LS9246 |
| 3. | Base Frame | 1 | 029-004 |
| 4. | Push Handle (<i>c/w fixing screws, nuts & washers</i>) | 1 | 029-111 |
| 5. | Push Handle hand grips | 2 | HGSL1 |
| 6. | RH outer lifting arm | 1 | 029-201R |
| 7. | LH outer lifting arm | 1 | 029-201L |
| 8. | RH Inner lifting arm | 1 | 029-200R |
| 9. | LH Inner lifting arm | 1 | 029-200R |
| 10. | Seat Frame | 1 | 029-207 |
| 11. | Upper “U” Bracket | 1 | 029-208 |
| 12. | M16 x 80 plain shank bolts | 4 | 029-203C |

| Ref No. | Description | Qty | Part No. |
|---------|--|-----|--------------------|
| 13. | M16 x 100 plain shank bolts | 2 | 029-203B |
| 14. | M16 x 140 plain shank bolts | 2 | 029-203A |
| 15. | 16mm washers | 16 | W16 |
| 16. | M16 Nyloc nuts | 8 | N16 |
| 17. | 50 O/D x 3 x 16mm hole Nylon Washers | 10 | 029-202 |
| 18. | M10 x 40 Socket head plain shank set screws (<i>for actuator mountings</i>). | 3 | SH1040 |
| 19. | M10 x 40 Socket head plain shank set screws (<i>for seat frame mountings</i>). | 2 | SH1040 |
| 20. | 10mm Washers | 10 | W10 |
| 21. | M10 Nyloc Nuts | 5 | N10 |
| 22. | Plain shank pivot pin tapped M12 at each end | 1 | 029-206 |
| 23. | M12 Washers | 2 | W12 |
| 24. | M12 Nyloc nuts | 2 | N12 |
| 25. | 30 O/D x 3 x 10mm hole Nylon Washer | | 029-204 |
| 26. | Lifting Actuator | 1 | LS9010 |
| 27. | Tilting Actuator | 1 | LS9015 |
| 28. | Hand Control | 1 | LS9025 |
| 29. | Controller (<i>c/w with mounting bracket</i>) | 1 | LS9020 & LS9030 |
| 30. | Battery | 1 | LS9040 |
| 31. | Battery Charger (<i>c/w with mounting bracket</i>) | 1 | LS9035 & LS9031 |

11. Trouble Shooting

| Symptom | Possible cause | Action |
|--|--|--|
| No motor sound or movement of piston the rod. | <ul style="list-style-type: none"> • The actuator is not connected to the control box • Blown fuse in the control box • Cable damaged | <ul style="list-style-type: none"> • Connect the actuator to the control box. • Fuse must be changed. • Send actuator for repair. |
| Excessive electricity consumption. | | <ul style="list-style-type: none"> • Send actuator for repair. |
| Actuator motor runs but piston rod does not move. | <ul style="list-style-type: none"> • Gear wheel of spindle damaged. | <ul style="list-style-type: none"> • Send actuator for repair. |
| Piston rod will only move inwards and not outwards | <ul style="list-style-type: none"> • Safety nut has operated | <ul style="list-style-type: none"> • Send actuator for repair. |
| Motor runs too slowly or does not give full force | <ul style="list-style-type: none"> • Insufficient power | <ul style="list-style-type: none"> • Charge battery |